

Product Specification
SFP+ 10 GBASE-LRM, 1310 nm, Linear Transceiver
TRX10GDL0610



Features

- Compliant to SFP+ Electrical MSA SFF-8431
- Compliant to SFP+ Mechanical MSA SFF-8432
- Transmission distance up to 220m (OM1 fiber)
- Low power consumption: 1.2W (Typ.)
- 0°C to +70°C case operating temperature range
- Laser Class 1 IEC / CDRH compliant
- RoHS 6/6 compliant
- Compliant with product safety standards

MergeOptics' **SFP+ LRM** is an optical transceiver module for transmission at 1310nm over legacy multi mode fiber. Supporting 10GBASE-LRM Ethernet standard make it ideally suited for 10G datacom. Its very low power consumption and its excellent EMI performance allow system design with high port density. The small form factor integrates a 1310nm distributed feedback laser (DFB) in an LC package and a linear multimode PIN receiver. MergeOptics module is lead free, RoHS compliant and is designed and tested in accordance with industry safety standards.

Supported Standards

Application	Standard	Data Rate
IEEE 802.3aq-2006	10 GBASE-LRM	10.3125 GBd

Table of Contents

Table of Contents	2
1. Functional Description.....	3
2. Technical Data	4
2.1. Electrical Characteristics.....	4
2.1.1. Absolute Maximum Ratings.....	4
2.1.2. Recommended Operating Conditions	4
2.1.3. Low Speed Characteristics.....	4
2.1.4. SFI Module Transmitter Input Characteristics.....	5
2.1.5. SFI Module Receiver Output Characteristics	5
2.2. Optical Characteristics	6
2.2.1. General Parameters	6
2.2.2. Optical Transmitter	6
2.2.3. Optical Receiver	6
3. Application Information	7
3.1. Connector Pinout.....	7
3.2. Electrical Pin Definition.....	7
3.3. Application Schematics	8
4. Interfacing the Transceivers.....	9
4.1. Module Identifier & Specific Data	9
4.2. Digital Optical Monitoring	9
5. Eye Safety.....	10
6. Module Outline.....	11
7. Regulatory Compliance	12
7.1. Module Safety	12
7.2. ESD & Electromagnetic compatibility.....	12
8. Ordering Information.....	13

1. Functional Description

The Transceivers convert information from electrical to optical format, and back again.

The transmit path consists of an AC coupled 100 ohm differentially terminated driver coupled to a highly reliable 1310nm DFB. The laser output may be disabled by pulling the TX_DISABLE line high. The laser is also disabled if this line is left floating, as it is pulled high inside the transceiver. The RATE_SELECT is not implemented in the LRM module.

The receiver path consists of a linear ROSA (receiver optical sub-assembly) for optical electrical conversion, followed by a linear amplifier to boost the electrical signal. A LOSS_OF_SIGNAL (LOS) status line is provided to facilitate easy link detection.

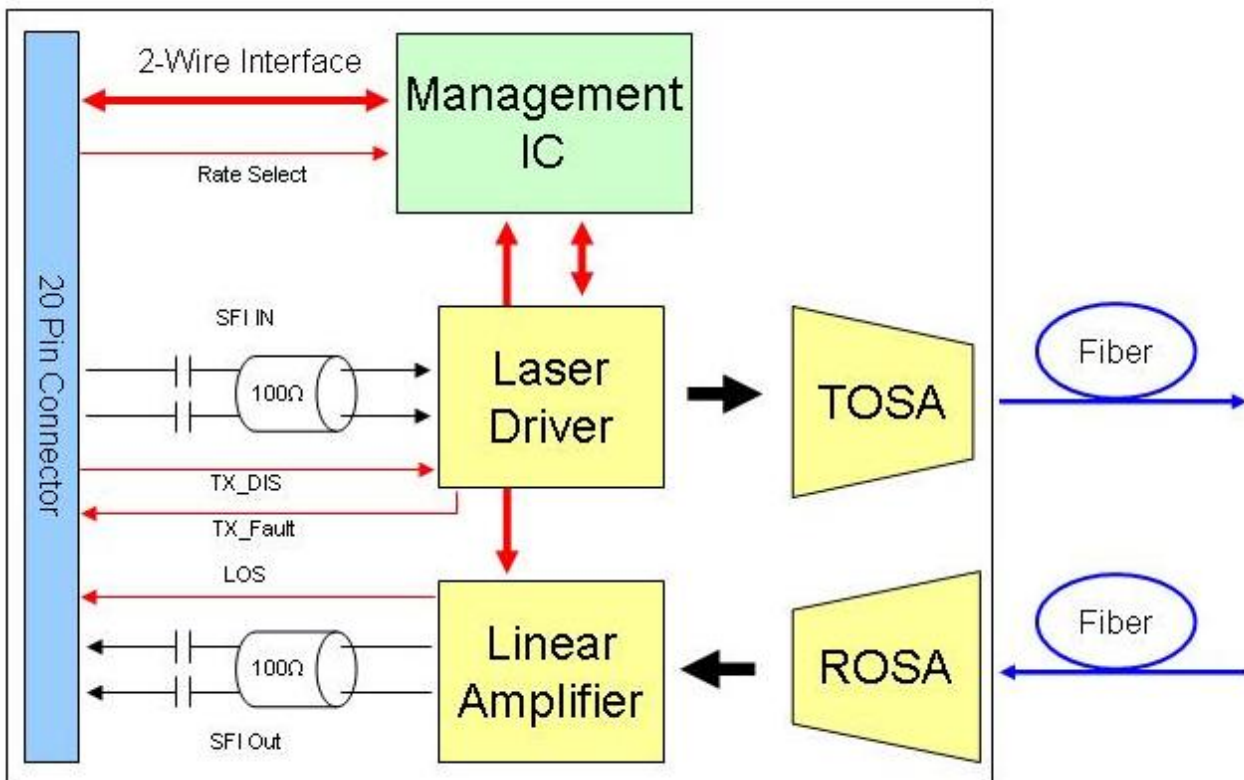

2. Technical Data

2.1. Electrical Characteristics

2.1.1. Absolute Maximum Ratings

Rating	Conditions	Symbol	Min	Max	Units
Storage Ambient Temperature Range		ϑ_{stg}	-40	+85	°C
Powered Case Temperature Range		ϑ_c	0	+75	°C
Operating Relative Humidity	Non condensing	RH	0	95	%
Supply Voltage Range @ 3.3V		V_{CC3}	-0.5	3.6	V
Open Drain VCC Level		V_{OD}		4.0	V
Static Discharge Voltage on High Speed Pins	HBM human body model per JEDEC JESD22-A114-B			1	kV
Static Discharge Voltage excluding High Speed Pins	HBM human body model			2	kV
Static Discharge Voltage on SFP+ Module	EN61000-4-2 Criterion B: Air Discharge Direct Contact discharge			15 8	kV

Any stress beyond the maximum ratings may result in permanent damage to the device. Specifications are guaranteed only under recommended operating conditions.

2.1.2. Recommended Operating Conditions

Parameter	Conditions	Symbol	Min	Typ	Max	Units
Operating Case Temperature Range	altitude of < 3km	ϑ_{Case}	0		+70	°C
Power Supply Voltage @ 3.3V		V_{CC3}	3.135	3.300	3.465	V
DC Common Mode Voltage		V_{CM}	0		3.6	V

2.1.3. Low Speed Characteristics

Parameter	Conditions	Symbol	Min	Typ	Max	Units
Supply Current Transmitter	@ V_{CCTX}	$I_{VCC TX}$		290		mA
Supply Current Receiver	@ $V_{CCR X}$	$I_{VCC RX}$		65		mA
Power Consumption				1.2	1.5	W
TX_Fault, RX_LOS, SCL, SDA	Host Vcc Range 2V – 3.46V	V_{OL}	0		0.4	V
		V_{OH}	Host_Vcc – 0.5		Host_Vcc + 0.3	
TX_Dis	Low Voltage TTL	V_{IL}	-0.3		0.8	
		V_{IH}	2.0		VccT + 0.3	
SCL, SDA	Host Vcc Range 3.14V – 3.46V	V_{IL}	-0.3		VccT* 0.3	
		V_{IH}	VccT* 0.7		VccT + 0.5	
		V_{OL}	0.0		0.4	
		V_{OH}	Host_Vcc – 0.5		Host_Vcc + 0.3	

Product Specification

SFP+ Multimode LRM

1310 nm Transceiver



2.1.4. SFI Module Transmitter Input Characteristics

Parameter	Conditions	Symbol	Min	Typ	Max	Units
Supported Data Rate		V_{ID}		10.3125		Gbd
Reference Differential Input Impedance		Z_d		100		Ω
Input AC Common Mode Input Voltage			0		25	mV (RMS)
Differential Input Voltage Swing		V_{ID}	180		700	mV
Differential Input S-parameter	0.01 – 3.9GHz	SDD11	1)		-10	dB
	3.9 – 11.1GHz				1)	dB
Differential to Common Mode Conversion ²⁾	0.01 – 11.1Ghz	SCD11			-10	dB
Total Jitter		TJ			0.28	UI(p-p)
Data Dependant Jitter		DDJ			0.1	UI(p-p)
Uncorrelated Jitter		UJ			0.023	RMS
Eye Mask	See SFP+ MSA	X1			0.14	UI
		X2			0.35	UI

1) Differential Return Loss given by equation $SDD11(dB) = -8 + 13.33 \log_{10}(f/5.5)$, with f in GHz

2) Common mode reference impedance is 25 Ω . Differential to common mode conversion relates to generation of EMI

2.1.5. SFI Module Receiver Output Characteristics

Parameter	Conditions	Symbol	Min	Typ	Max	Units
Supported Data Rate			2	10.3125		Gbd
Reference Differential Output Impedance		Z_d		100		Ω
Termination Mismatch		ΔZ_d			5	%
Output AC Common Mode Voltage					15	mV (RMS)
Output Rise and Fall time	20% to 80%	t_{RH}, t_{FH}	24		35	ps
Differential Output S-parameter	0.01 – 3.9GHz	SDD22			-10	dB
	3.9 – 11.1GHz				1)	dB
Common Mode Output Return Loss ²⁾	0.01 – 6.5GHz	SCC22			-7	dB
	6.5 – 11.1GHz				-3	dB
Relative Noise		dRN			tbd	RMS
Module Receiver Waveform Distortion Penalty		dWDP			1.5	dB
Differential Voltage Modulation Amplitude		VMA	180		600	mVp-p

1) Return Loss given by equation $Sxx22(dB) = -8 + 13.33 \log_{10}(f/5.5)$, with f in GHz

2) Common mode reference impedance is 25 Ω . Common mode return loss helps absorb reflection and noise improving EMI

Product Specification

SFP+ Multimode LRM

1310 nm Transceiver



2.2. Optical Characteristics

2.2.1. General Parameters

Parameter	Conditions	Min Modal Bandwidth (MHz*km)	Symbol	Operating Range	Units
Operating Range	62.5um MMF OM1 50um MMF OM2 50um MMF OM3	160/500 500/500 1500/500	I_{OP}	0.5 to 220 0.5 to 220 0.5 to 220	km

2.2.2. Optical Transmitter

Parameter	Conditions	Symbol	Min	Typ	Max	Units
Nominal Wavelength		λ_{TRP}	1290	1310	1330	nm
RMS spectral width		RMS			2.4	dB
Average Launch Power		P_{avg}	-6.5		0.5	dBm
Optical Modulation Amplitude		P_{OMA}	-4.5		1.5	dBm
Extinction Ratio		ER	3.5			dB
Relative Intensity Noise		RIN			-128	dB/Hz

2.2.3. Optical Receiver

Parameter	Conditions	Symbol	Min	Typ	Max	Units
Maximum Input Power		P_{MAX}			0.5	dBm
Center Wavelength		λ_C	1260	1310	1355	nm
Overload	OMA	P_{Sat}	1.5			dBm
Stressed Receiver Sensitivity	OMA, PRBS $2^{31}-1$, BER < $1 \cdot 10^{-12}$ @10.3125GBd	P_{IN}	-6.5			dBm
Stressed Receiver Sensitivity Symmetrical Test	OMA, PRBS $2^{31}-1$, BER < $1 \cdot 10^{-12}$ @10.3125GBd	P_{IN}	-6			dBm
Unstressed Receiver Sensitivity	OMA, PRBS $2^{31}-1$, BER < 10^{-12} @10.3125Gbd	P_{in}	-12			dBm
Loss of Signal		P_{av_as}	-25			dBm
		P_{OMA_deas}			-21	

Note: The specified characteristics are met within the recommended range of operating. Unless otherwise noted typical data are quoted at nominal voltages and +25°C ambient temperature.

3. Application Information

3.1. Connector Pinout

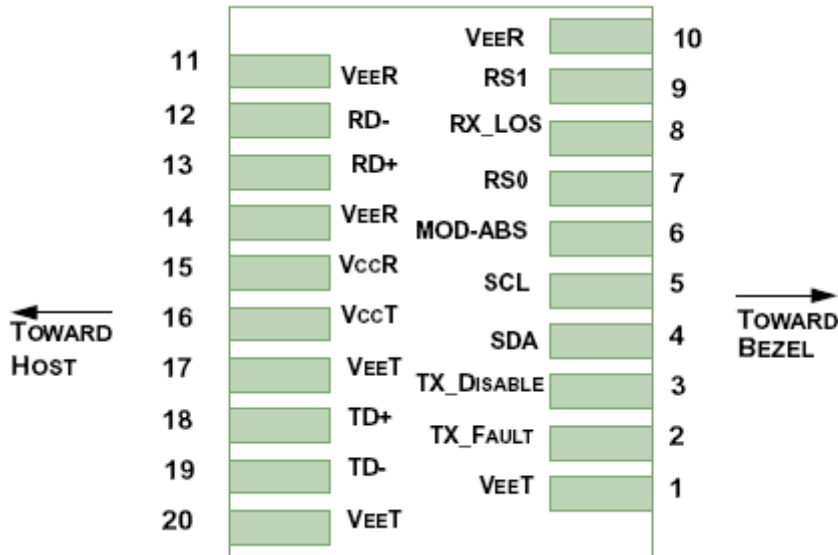

3.2. Electrical Pin Definition

PIN	Logic	Symbol	Name / Description	Note
1		VeeT	Module Transmitter Ground	1
2	LVTTL-O	TX_Fault	Module Transmitter Fault	
3	LVTTL-I	TX_Dis	Transmitter Disable; Turns off transmitter laser output	
4	LVTTL-I	SCL	2-Wire Serial Interface Clock	2
5	LVTTL-I/O	SDA	2-Wire Serial Interface Data Line	2
6		MOD_DEF0	Module Definition, Grounded in the module	
7	LVTTL-I	RS0	No function implemented	
8	LVTTL-O	RX_LOS	Receiver Loss of Signal Indication Active LOW	
9	LVTTL-I	RS1	No function implemented	
10		VeeR	Module Receiver Ground	1
11		VeeR	Module Receiver Ground	1
12	CML-O	RD-	Receiver Inverted Data Output	
13	CML-O	RD+	Receiver Data Output	
14		VeeR	Module Receiver Ground	1
15		VccR	Module Receiver 3.3 V Supply	
16		VccT	Module Receiver 3.3 V Supply	
17		VeeT	Module Transmitter Ground	1
18	CML-I	TD-	Transmitter Inverted Data Input	
19	CML-I	TD+	Receiver Non-Inverted Data Output	
20		VeeT	Module Transmitter Ground	1

1. Module ground pins GND are isolated from the module case.
2. Shall be pulled up with 4.7K-10Kohms to a voltage between 3.15V and 3.45V on the host board.

Product Specification

SFP+ Multimode LRM

1310 nm Transceiver



3.3. Application Schematics

Recommended electrical connections to transceiver are shown below.

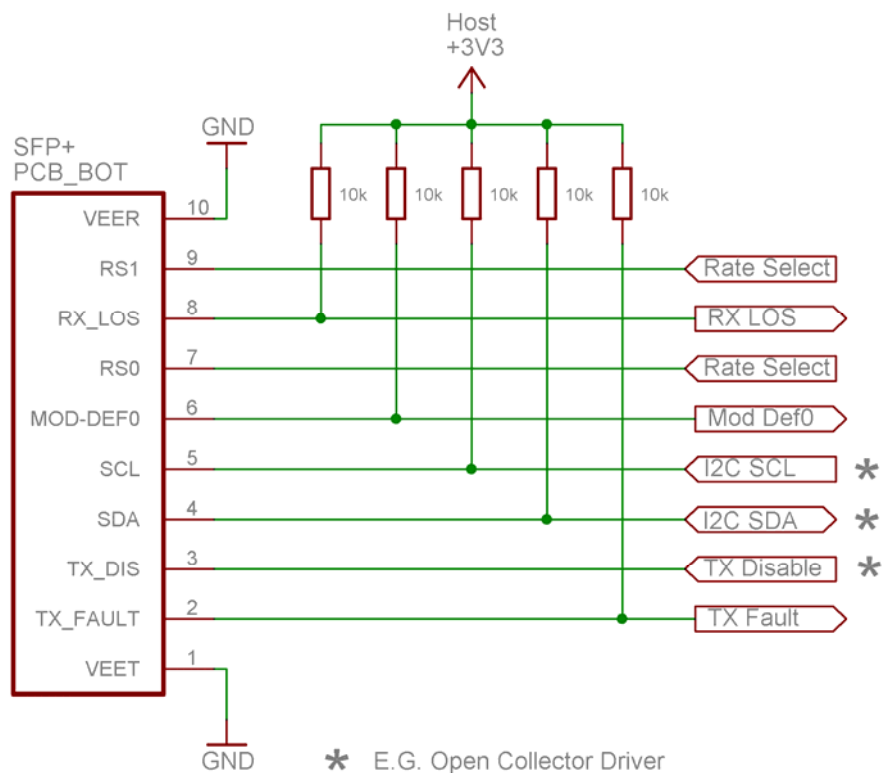
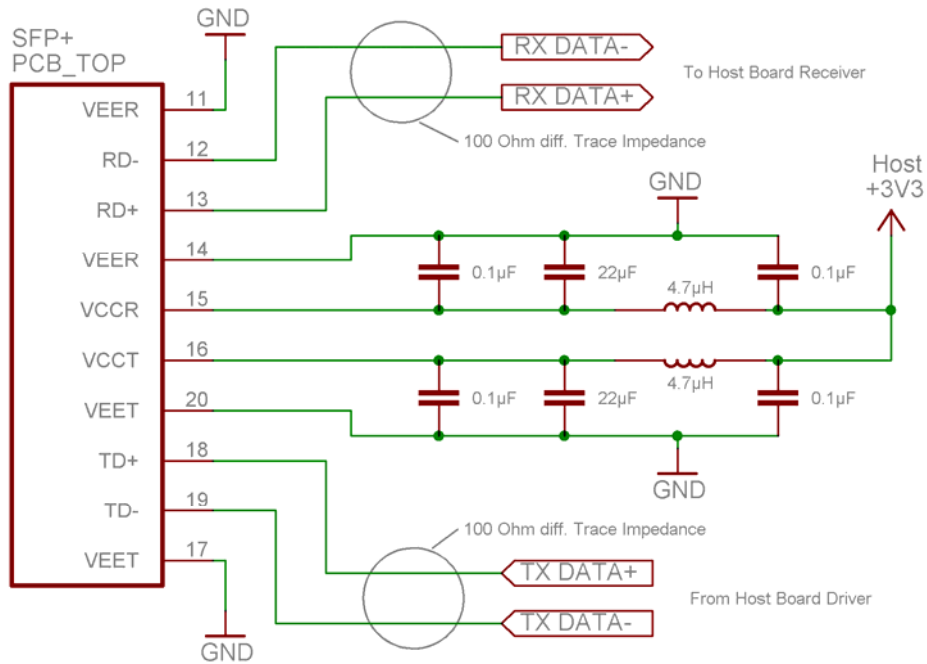

4. Interfacing the Transceivers

Communication is done by a serial 2-wire interface similar to the I2C bus protocol. As described in the document SFF-8472 there are two distinct address spaces:

Base Address A0(hex)	
Byte Address	Content
0 - 95	Serial Transceiver ID as defined in SFP MSA
96 - 127	MergeOptics Specific
128 - 255	Reserved

Base Address A2(hex)	
Byte Address	Content
0 - 55	Alarm & Warnings thresholds & limits
56 - 95	External calibration constants (not used)
96 - 119	Values from real time diagnostic monitoring
120 - 127	Not used
128 - 247	Customer specific, writable area
248 - 255	Not used

4.1. Module Identifier & Specific Data

Refer to SFF-8472 for a detailed listing of registers

4.2. Digital Optical Monitoring

Transceivers offer the ability to monitor important module parameter during operation. The five parameters listed below are continuously monitored for getting information about the current module status. All data is calibrated internally; there is no need for external post processing.

Temperature

Internally measured temperature data is represented as two's complement of a signed 16-bit value in increments of 1/256 °C over a range of -40 to +100°C. Accuracy is better than +/-3%.

Supply Voltage (VCC)

Internally measured supply voltage. Represented as a 16-bit unsigned integer with the voltage defined as the full 16 bit value (0 – 65535) with LSB equal to 100 µVolt, which yields to a total range of 0 to +6.55 Volts. Accuracy is better than +/-3%.

Laser Bias Current

VCSEL bias current. Represented as a 16 bit unsigned integer with the current defined as the full 16-bit value (0 – 65535) with LSB equal to 2 µA, valid range is 0 to 20 mA. Accuracy is better than +/-10%.

Optical Transmitter Power

TX output power measurement is based on internal monitor diode feedback. Represented as a 16-bit unsigned integer with the power defined as the full 16 bit value (0 – 65535) with LSB equal to 0.1 µW. Accuracy is better than +/-3dB over a range of $P_{av_{min}}$ to $P_{av_{max}}$.

Product Specification

SFP+ Multimode LRM

1310 nm Transceiver



Receiver Optical Power

RX input power measurement is based on photodiode diode current. Represented as a 16-bit unsigned integer with the power defined as the full 16 bit value (0 – 65535) with LSB equal to 0.1 μ W. Accuracy is better than +/-3dB over a range of -12dBm to -1dBm.

Note: The specified characteristics are met within the recommended range of operating conditions regarding temperature and voltage.

5. Eye Safety

This laser based multimode transceiver is a Class 1 product. It complies with IEC 60825-1: 2007 and FDA performance standards for laser products (21 CFR 1040.10 and 1040.11) except for deviations pursuant to Laser Notice 50, dated June 24, 2007.

CLASS 1 LASER PRODUCT

Caution: use of controls or adjustments or performance of procedures other than those specified herein may result in hazardous radiation.

Note: All adjustments have been made at the factory prior to shipment of the devices. No maintenance or alteration to the device is required. Tampering with or modifying the performance of the device will result in voided product warranty. Failure to adhere to the above restrictions could result in a modification that is considered an act of “manufacturing”, and will require, under law, recertification of the modified product with the U.S. Food and Drug Administration (ref. 21 CFR 1040.10 (i)).

Laser Emission Data

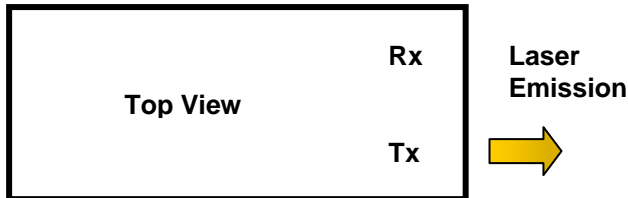

Wavelength	1310 nm
Maximum total output power (as defined by IEC: 7 mm aperture at 70 mm distance)	15.6 mW / 11.9 dBm
Beam divergence (full angle) / NA (half angle)	11° / 0.1 rad

Required Labeling

FDA

Compliant to 21 CFR
1040.10 and 1040.11

IEC

Class 1 Laser Product

6. Module Outline

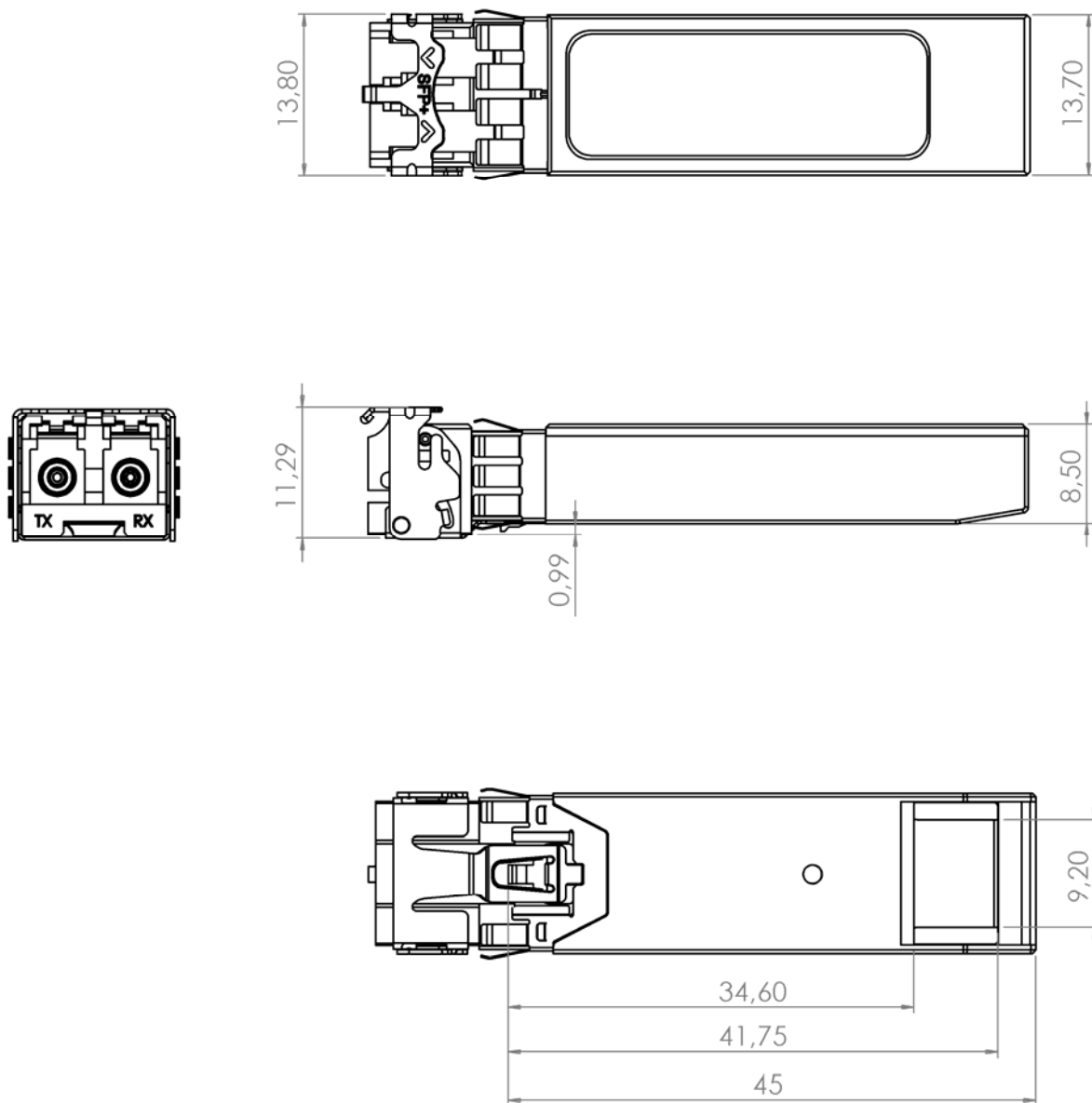

All dimensions shown are in millimeters.

7. Regulatory Compliance

7.1. Module Safety

MergeOptics SFP+ LR modules are designed to meet international requirements and standards in terms of product safety. Tests were performed according to IEC 60950-1:2001 (CB scheme). The module is RoHS compliant according to the European Parliament requirements on the restriction of the use of hazardous substances in electrical and electronic equipment (RoHS). The modules optical output power meet Class 1 requirements for laser safety.

Requirements	Standard	Status
Module Safety	IEC 60950-1:2001 EN 60950-1:2001	TUV Report / Certificate available CB Report / Certificate available
RoHS Compliance	RoHS Directive 2002/95/EC Amendment 4054 (2005/747/EC)	RoHS 6/6 compliant Certificate of compliance available
Laser Eye Safety	CDRH 21 CFR 1040.10 and 1040.11 IEC 60825-1 Rev2 2007	Laser Class 1 according to FDA Laser Class 1 according to IEC Rev2

7.2. ESD & Electromagnetic compatibility

MergeOptics SFP+ LR modules are designed to withstand high ESD voltages. Its excellent performances in terms of EMI allow system designers to integrate the module in high density applications.

Requirements	Standard	Status
Electro Static Discharge to the Electrical Pins (ESD)	EIA/JESD22-A114-B MIL-STD 883C Method 3015.7	Exceeds requirements Class 1B (>1000V)
Immunity to ESD (housing, receptable)	IEN 61000-4-2 IEC61000-4-2	Exceeds requirements Discharges ranging from 2kV to 25kV without damages to the transceiver
Electromagnetic Emission (EMI)	FCC Part 15, Class B EN 55022 Class B CISPR 22	Exceeds requirements Class B with more than 6dB margin

Product Specification

SFP+ Multimode LRM

1310 nm Transceiver



8. Ordering Information

Part Number Coding Scheme

TRX	10G	D	L	06	10
Transceiver	Data Rate	Source	Photodiode	Standard	MSA
	10G 10 Gbit/s	D DFB	L Linear	6 10G LRM	10 SFP+

Overview Part Number Products

Application	Standard	Limiting Interface
10G Ethernet LRM	IEEE 802.3aq-2006 10GBASE-LRM	TRX10GDL0610

For further information please contact us at info@mergeoptics.com