

Product Specification

Multirate 8.5Gb/s Fibre Channel SFP+

850nm Limiting Transceiver TRX08GVP2510



Product Specification

8.5Gb/s SFP+ 850nm Limiting Transceiver

TRX08GVP2510



Product Features

- Hot pluggable
- Low power consumption, 0.5W (typical)
- Multi rate 2G/4G/8G Fibre Channel Applications
- Excellent EMI Performance
- Transmission distance up to 150m OM3 MMF
- 850nm VCSEL
- Serial ID and digital diagnostic Interface through I2C
- 0°C to +70°C case operating temperature
- Laser Class 1
- RoHS 6/6 compliant

Applications:

2G/4G/8G Fiber Channel

MergeOptics' SFP+ optical transceiver TRX08GVP2510 is compliant with the current SFP+ MSA specifications (SFF-8431 and SFF-8432). It is compliant with FC-PI-4 800-Mx-SN-I. It is RoHS 6/6 compliant per Directive 2002/95/EC and laser class 1 safety compliant per IEC/CDRH. The sub watt power consumption and the excellent EMI performance allow system design with high port density.

Supported Standards

| Application | Standard | Data Rate |
|------------------|-----------------------------------|-----------|
| 8G Fibre Channel | FC-PI-4 800-Mx-SN-S, 800-M5E-SN-I | 8.5Gb/s |
| 4G Fibre Channel | FC-PI-4 400-Mx-SN-I | 4.25Gb/s |
| 2G Fibre Channel | FC-PI-4 200-Mx-SN-I | 2.125Gb/s |

Table of Contents

| | |
|---|-----------|
| Table of Contents | 2 |
| 1. Functional Description..... | 3 |
| 2. Electrical Characteristics..... | 4 |
| 2.1. Absolute Maximum Ratings | 4 |
| 2.2. Recommended Operating Conditions..... | 4 |
| 2.3. Low Speed Characteristics | 4 |
| 2.4. SFI Module Transmitter Input Characteristics | 4 |
| 2.5. SFI Module Receiver Output Characteristics..... | 5 |
| 3. Optical Characteristics | 6 |
| 3.1. General Parameters..... | 6 |
| 3.2. Optical Transmitter..... | 6 |
| 3.3. Optical Receiver..... | 6 |
| 4. Application Information | 7 |
| 4.1. Connector Pinout | 7 |
| 4.2. Electrical Pin Definition | 7 |
| 4.3. Application Schematics..... | 8 |
| 4.4. Interfacing the Transceiver | 9 |
| 4.5. Eye Safety..... | 10 |
| 5. Module Outline..... | 11 |
| 6. Related Information & Compliance..... | 12 |
| 7. Ordering Information..... | 12 |

Product Specification

Multirate 8.5Gbd Fibre Channel SFP+

850nm Limiting Transceiver TRX08GVP2510



1. Functional Description

The transmit path is based on an AC coupled 100 ohm differentially terminated driver coupled to an 850nm VCSEL. Laser output may be disabled by pulling the transmitter disable (TX_DIS) line high. Due to an internal pull-up resistor this is the default state when leaving input floating. A fault condition flag is set upon detection of laser failure.

The receive path consists of a receiver optical sub-assembly (ROSA) for optical to electrical conversion, followed by a limiting amplifier boosting the electrical signal. A loss of signal (LOS) status line provides information to facilitate easy link detection.

Complete digital optical monitoring is implemented in compliance to SFF-8472 and made accessible via the 2-wire interface providing real time information about all important module parameters and status information.

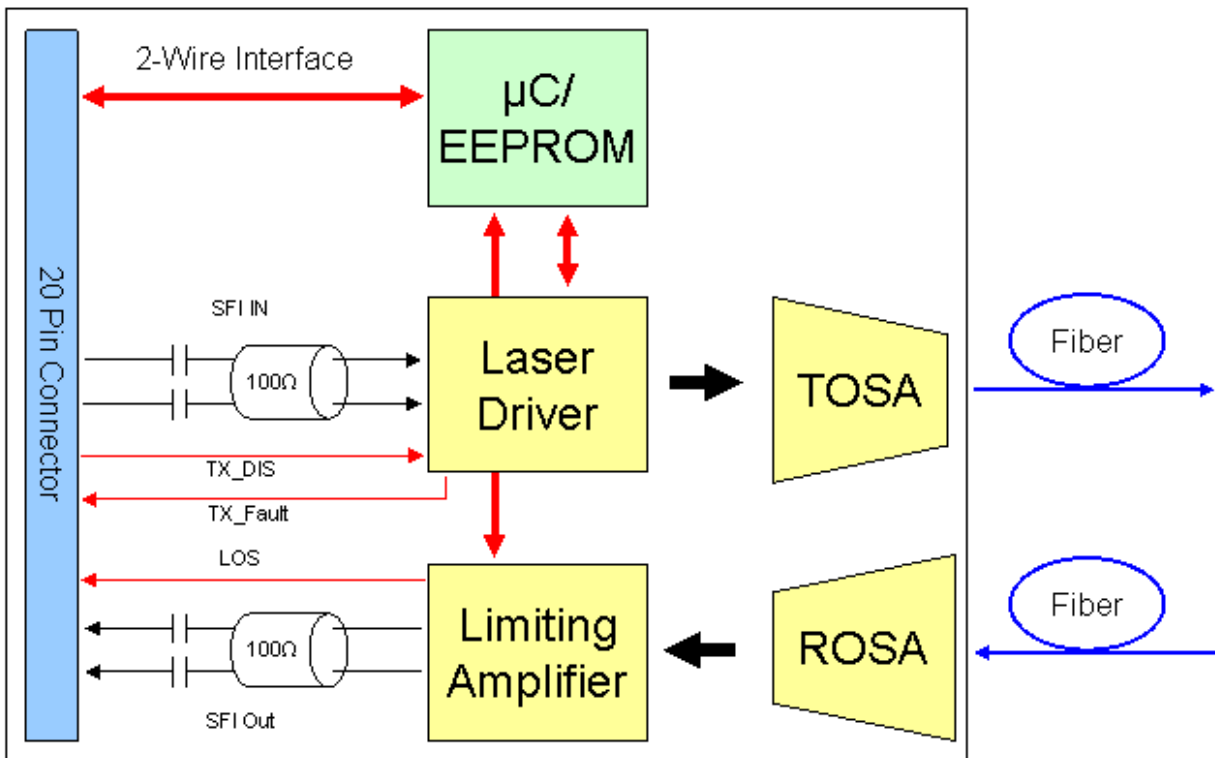

Product Specification

Multirate 8.5Gbd Fibre Channel SFP+

850nm Limiting Transceiver TRX08GVP2510



2. Electrical Characteristics

2.1. Absolute Maximum Ratings

| Rating | Conditions | Symbol | Min | Max | Units |
|-----------------------------|----------------|-------------------|------|-----|-------|
| Storage Ambient Temperature | | ϑ_{stg} | -40 | +85 | °C |
| Powered Case Temperature | | ϑ_c | 0 | +75 | °C |
| Operating Relative Humidity | Non condensing | RH | 0 | 95 | % |
| Supply Voltage Range | | V_{CC3} | -0.5 | 4.0 | V |

Any stress beyond the maximum ratings may result in permanent damage to the device. Specifications are guaranteed only under recommended operating conditions.

2.2. Recommended Operating Conditions

| Parameter | Conditions | Symbol | Min | Typ | Max | Units |
|----------------------------|-------------------|--------------------|-------|------|-------|-------|
| Operating Case Temperature | altitude of < 3km | ϑ_{Case} | 0 | | +70 | °C |
| Power Supply Voltage | | V_{CC3} | 3.135 | 3.30 | 3.465 | V |
| DC Common Mode Voltage | | V_{CM} | 0 | | 3.6 | V |

2.3. Low Speed Characteristics

| Parameter | Conditions | Symbol | Min | Typ | Max | Units |
|----------------------------|------------------------------|-------------|-------------------|-----|-------------------|-------|
| Supply Current Transmitter | @ V_{CCTX} | I_{VCCTX} | | | 90 | mA |
| Supply Current Receiver | @ V_{CCRX} | I_{VCCRX} | | | 120 | mA |
| Power Consumption | | | | 0.5 | 0.7 | W |
| TX_Fault, RX_LOS | Host Vcc Range 2V – 3.47V | V_{OL} | 0 | | 0.4 | V |
| | | V_{OH} | Host_Vcc – 0.5 | | Host_Vcc + 0.3 | |
| TX_Dis, RS0, RS1 | Low Voltage TTL | V_{IL} | -0.3 | | 0.8 | |
| | | V_{IH} | 2.0 | | $V_{CC3} + 0.3$ | |
| SCL, SDA | Host Vcc Range 3.14V – 3.47V | V_{IL} | -0.3 | | $V_{CC3}^* + 0.3$ | |
| | | V_{IH} | $V_{CC3}^* + 0.7$ | | $V_{CC3} + 0.5$ | |
| | | V_{OL} | 0.0 | | 0.4 | |
| | | V_{OH} | Host_Vcc – 0.5 | | Host_Vcc + 0.3 | |

2.4. SFI Module Transmitter Input Characteristics

| Parameter | Conditions | Symbol | Min | Typ | Max | Units |
|--|------------|----------|-------|-----|-----|----------|
| Nominal Data Rate | | V_{ID} | 2.125 | 8.5 | | Gbd |
| Reference Differential Input Impedance | | Z_d | | 100 | | Ω |
| Input AC Common Mode Input Voltage | | | 0 | | 25 | mV (RMS) |

Product Specification

Multirate 8.5Gbd Fibre Channel SFP+

850nm Limiting Transceiver TRX08GVP2510



| | | | | | | |
|--|----------------|----------|---------------|--|---------------|---------|
| Differential Input Voltage Swing | | V_{ID} | 150 | | 900 | mV |
| Differential Input S-parameter | 0.01 – 3.9GHz | SDD11 | | | -10 | dB |
| | 3.9 – 11.1GHz | | ¹⁾ | | ¹⁾ | dB |
| Differential to Common Mode Conversion ²⁾ | 0.01 – 11.1GHz | SCD11 | | | -10 | dB |
| Total Jitter | | TJ | | | 0.28 | UI(p-p) |
| Data Dependant Jitter | | DDJ | | | 0.1 | UI(p-p) |
| Uncorrelated Jitter | | UJ | | | 0.023 | RMS |

- 1) Differential Return Loss given by equation $SDD11(dB) = -8 + 13.33 \log_{10}(f/5.5)$, with f in GHz
 2) Common mode reference impedance is 25Ω. Differential to common mode conversion relates to generation of EMI

2.5. SFI Module Receiver Output Characteristics

| Parameter | Conditions | Symbol | Min | Typ | Max | Units |
|--|---------------------------------------|------------------|-------|-----|---------------|----------|
| Nominal Data Rate | | | 2.125 | 8.5 | | Gbd |
| Reference Differential Output Impedance | | Z_d | | 100 | | Ω |
| Termination Mismatch | | ΔZ_d | | | 5 | % |
| Output AC Common Mode Voltage | | | | | 15 | mV (RMS) |
| Differential Output Amplitude | $R_{Load} = 100\Omega$, Differential | V_{OSPP} | 350 | | 800 | mV |
| Output Rise and Fall time | 20% to 80% | t_{RH}, t_{FH} | | | 35 | ps |
| Differential Output S-parameter | 0.01 – 3.9GHz | SDD22 | | | -10 | dB |
| | 3.9 – 11.1GHz | | | | ¹⁾ | dB |
| Common Mode Output Return Loss ²⁾ | 0.01 – 6.5GHz | SCC22 | | | -7 | dB |
| | 6.5 – 11.1GHz | | | | -3 | dB |
| Deterministic Jitter | | DJ | | | 0.42 | UI(p-p) |
| Total Jitter | See SFP+ MSA | TJ | | | 0.7 | UI(p-p) |

- 1) Return Loss given by equation $Sxx22(dB) = -8 + 13.33 \log_{10}(f/5.5)$, with f in GHz
 2) Common mode reference impedance is 25Ω. Common mode return loss helps absorb reflection and noise improving EMI

Product Specification

Multirate 8.5Gbd Fibre Channel SFP+

850nm Limiting Transceiver TRX08GVP2510



3. Optical Characteristics

3.1. General Parameters

| Parameter | Conditions | Min Modal Bandwidth (MHz*km) | Symbol | Min | Typical 1GBd | Typical 10GBd | Units |
|-----------------|-------------|------------------------------|-----------------|-----|--------------|---------------|-------|
| Operating Range | 62.5 µm MMF | 160 | I _{OP} | 2 | 220 | 26 | m |
| | 50 µm MMF | 400 | | 2 | 500 | 66 | |
| | 62.5 µm MMF | 200 | | 0.5 | 275 | 33 | |
| | 50 µm MMF | 500 | | 0.5 | 550 | 82 | |
| | 50 µm MMF | 2000 | | 0.5 | X | 300 | |

3.2. Optical Transmitter

| Parameter | Conditions | Symbol | Min | Typ | Max | Units |
|--------------------------|------------|------------------|------|-----|------|-------|
| Nominal Wavelength | | λ _{TRP} | 840 | 850 | 860 | nm |
| Spectral Width | | Δλ | | | 0.65 | |
| Average Launch Power | | P _{avg} | -8.0 | | -1 | dBm |
| Extinction Ratio | | ER | 3.5 | | | dB |
| Relative Intensity Noise | | RIN | | | -128 | dB/Hz |

3.3. Optical Receiver

| Parameter | Conditions | Symbol | Min | Typ | Max | Units |
|---------------------------------------|--|-----------------------|-------|-----|-----|-------|
| Maximum Input Power | | P _{MAX} | | | -1 | dBm |
| Center Wavelength | | λ _C | 840 | 850 | 860 | nm |
| Receiver Sensitivity | PRBS 2 ³¹ -1, BER < 1*10 ⁻¹² @8.5GBd | P _{IN(OMA)} | -11.2 | | | dBm |
| | PRBS 2 ³¹ -1, BER < 1*10 ⁻¹² @2.125GBd | | -13.1 | | | |
| Stressed Receiver Sensitivity | PRBS 2 ³¹ -1, BER < 1*10 ⁻¹² @8.5GBd | P _{IN(OMA)} | -8.2 | | | dBm |
| | PRBS 2 ³¹ -1, BER < 1*10 ⁻¹² @2.125GBd (M6) | | -9.6 | | | |
| Receiver 3 dB upper cut-off frequency | All data rates | F _{CutOff} | | | 10 | GHz |
| Loss of Signal | | P _{av_as} | -30 | | | dBm |
| | | P _{OMA_deas} | | | -14 | |

Note: The specified characteristics are met within the recommended range of operating. Unless otherwise noted typical data are quoted at nominal voltages and +25°C ambient temperature.

Attention

Receiver sensitivity at data rates lower than 8.5GBd may strongly depend on transmitter input signal as receiver cut-off frequency remain at bandwidth setting for 8.5GBd.

Product Specification

Multirate 8.5Gbd Fibre Channel SFP+

850nm Limiting Transceiver TRX08GVP2510



4. Application Information

4.1. Connector Pinout

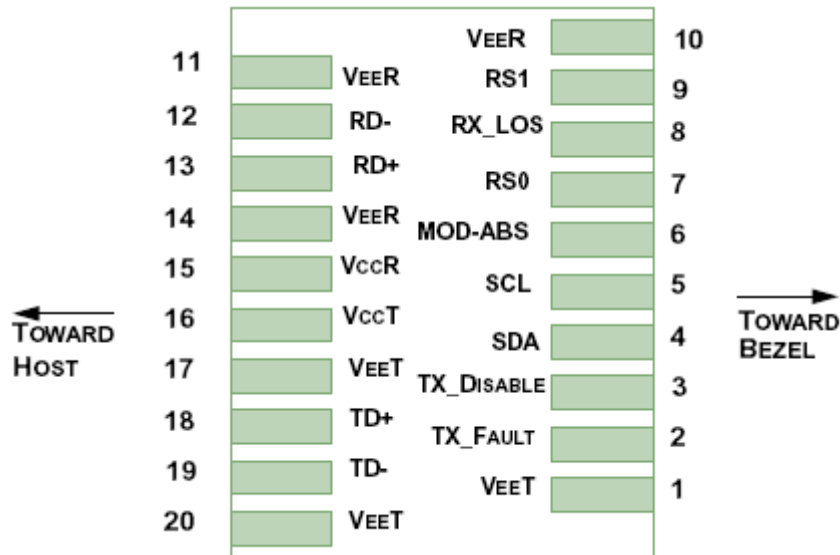

4.2. Electrical Pin Definition

| PIN | Logic | Symbol | Name / Description | Note |
|-----|-----------|----------|---|------|
| 1 | | VeeT | Module Transmitter Ground | 1 |
| 2 | LVTTL-O | TX_Fault | Module Transmitter Fault | |
| 3 | LVTTL-I | TX_Dis | Transmitter Disable; Turns off transmitter laser output | |
| 4 | LVTTL-I | SCL | 2-Wire Serial Interface Clock | 2 |
| 5 | LVTTL-I/O | SDA | 2-Wire Serial Interface Data Line | 2 |
| 6 | | MOD_DEF0 | Module Definition, Grounded in the module | |
| 7 | LVTTL-I | RS0 | Receiver Rate Select | |
| 8 | LVTTL-O | RX_LOS | Receiver Loss of Signal Indication Active LOW | |
| 9 | LVTTL-I | RS1 | Transmitter Rate Select | |
| 10 | | VeeR | Module Receiver Ground | 1 |
| 11 | | VeeR | Module Receiver Ground | 1 |
| 12 | CML-O | RD- | Receiver Inverted Data Output | |
| 13 | CML-O | RD+ | Receiver Data Output | |
| 14 | | VeeR | Module Receiver Ground | 1 |
| 15 | | VccR | Module Receiver 3.3 V Supply | |
| 16 | | VccT | Module Receiver 3.3 V Supply | |
| 17 | | VeeT | Module Transmitter Ground | 1 |
| 18 | CML-I | TD- | Transmitter Inverted Data Input | |
| 19 | CML-I | TD+ | Receiver Non-Inverted Data Output | |
| 20 | | VeeT | Module Transmitter Ground | 1 |

1. Module ground pins GND are isolated from the module case.
2. Shall be pulled up with 4.7K-10Kohms to a voltage between 3.15V and 3.45V on the host board.

Product Specification

Multirate 8.5Gbd Fibre Channel SFP+

850nm Limiting Transceiver TRX08GVP2510



4.3. Application Schematics

Recommended electrical connections to transceiver are shown below.

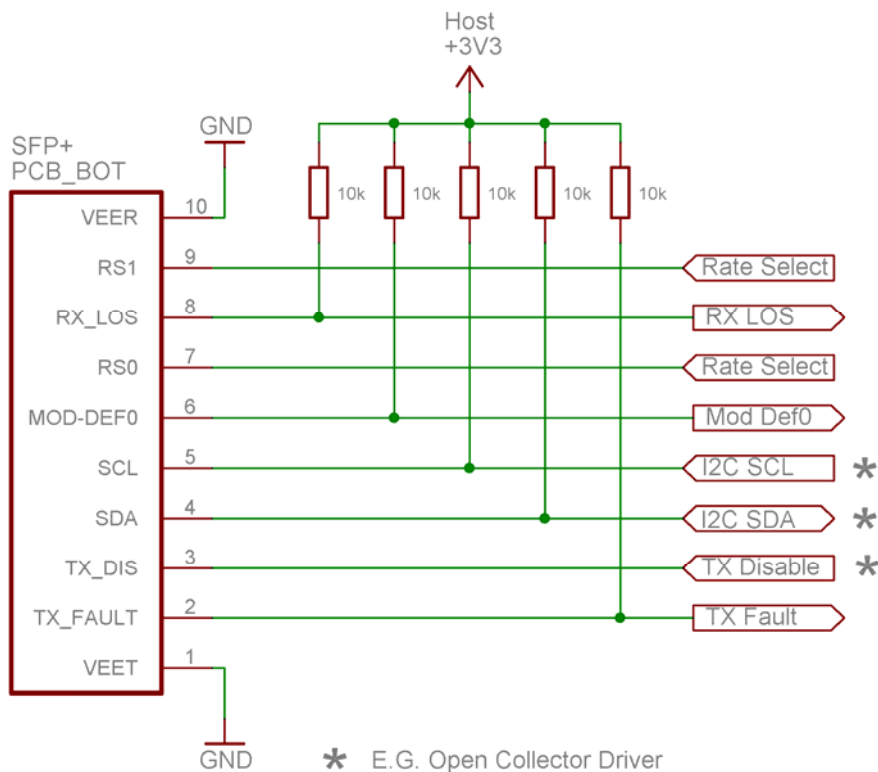
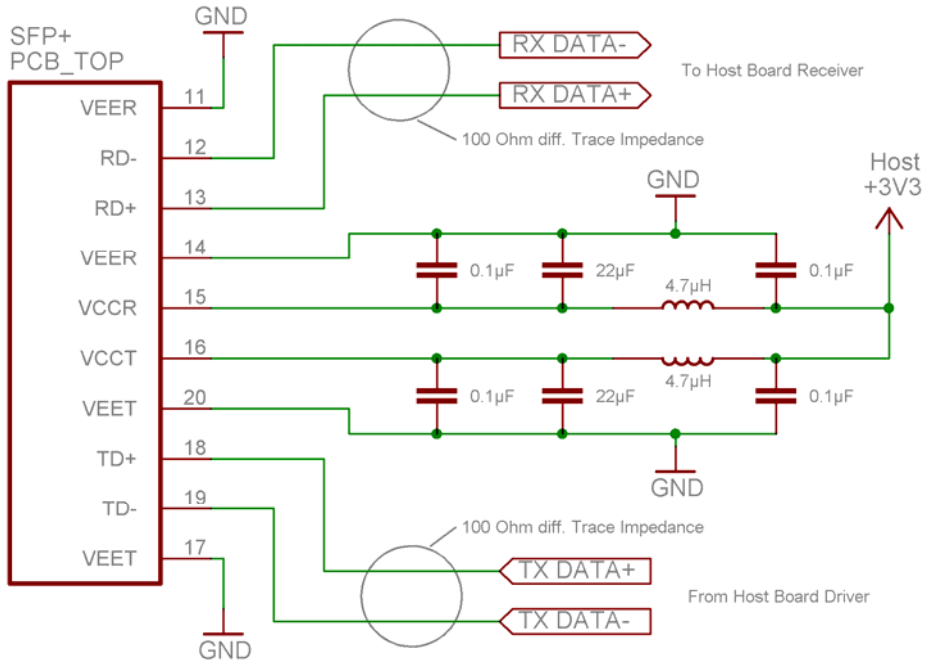

Product Specification

Multirate 8.5Gbd Fibre Channel SFP+

850nm Limiting Transceiver TRX08GVP2510



4.4. Interfacing the Transceiver

Communication is done by a serial 2-wire interface compatible to the I2C bus protocol. Refer to SFF-8472 for a more detailed register explanation of the registers:

| Base Address A0(hex) | |
|----------------------|---|
| Byte Address | Content |
| 0 - 95 | Serial Transceiver ID as defined in SFP MSA |
| 96 - 127 | MergeOptics Specific |
| 128 - 255 | Reserved |

| Base Address A2(hex) | |
|----------------------|---|
| Byte Address | Content |
| 0 - 55 | Alarm & Warnings Thresholds & Limits |
| 56 - 95 | External calibration constants (not used) |
| 96 - 119 | Values from real time diagnostic monitoring |
| 120 - 127 | Not used |
| 128 - 247 | Customer specific, writable area |
| 248 - 255 | Not used |

See memory map details in a separate app note.

Product Specification

Multirate 8.5Gb/s Fibre Channel SFP+ 850nm Limiting Transceiver TRX08GVP2510



4.5. Eye Safety

This laser based multimode transceiver is a Class 1 product. It complies with IEC 60825-1 Ed.2: 2007 and FDA performance standards for laser products (21 CFR 1040.10 and 1040.11) except for deviations pursuant to Laser Notice 50, dated June 24, 2007.

CLASS 1 LASER PRODUCT **DO NOT VIEW DIRECTLY WITH OPTICAL INSTRUMENTS**

Caution: use of controls or adjustments or performance of procedures other than those specified herein may result in hazardous radiation.

Note: All adjustments have been made at the factory prior to shipment of the devices. No maintenance or alteration to the device is required. Tampering with or modifying the performance of the device will result in voided product warranty. Failure to adhere to the above restrictions could result in a modification that is considered an act of "manufacturing", and will require, under law, recertification of the modified product with the U.S. Food and Drug Administration (ref. 21 CFR 1040.10

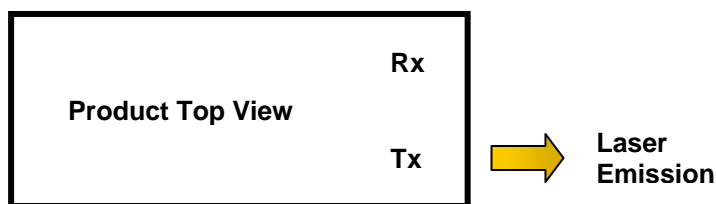

| | |
|---|--------------|
| Wavelength | >840 nm |
| Accessible Emission Limit (as defined by IEC: 7 mm aperture at 70 mm distance) | <743 μ W |

Product Specification

Multirate 8.5Gbd Fibre Channel SFP+

850nm Limiting Transceiver TRX08GVP2510



5. Module Outline

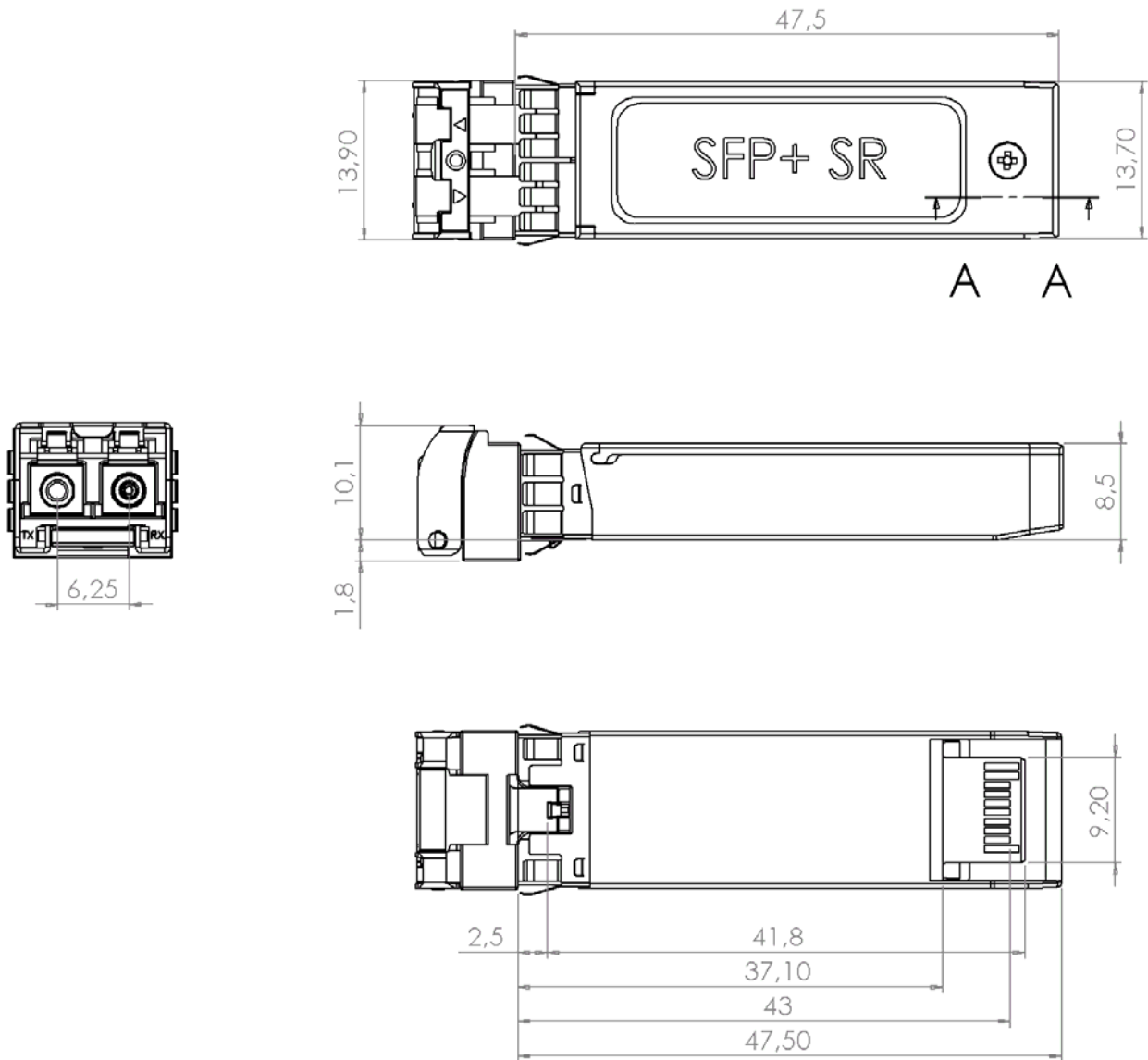

All dimensions shown are in millimeters.

Product Specification

Multirate 8.5Gb/s Fibre Channel SFP+

850nm Limiting Transceiver TRX08GVP2510



6. Related Information & Compliance

| Requirements | Standard |
|--------------|---|
| RoHS | RoHS 6/6 Directive 2002/95/EC Amendment 4054 (2005/747/EC) |
| EMI (Module) | FCC Part 15, Class B EN 55022 Class B CISPR 22 |

| Requirements | Standard | Value |
|----------------------------|--|-------|
| ESD (Electrical connector) | JEDEC JESD22-A114-B | 1kV |
| ESD (Module case) | Air Discharge EN61000-4-2 criterion B | 15kV |
| ESD (Module case) | Contact Discharge EN61000-4-2 criterion B | 8kV |

7. Ordering Information

| Application | Part No. |
|----------------------------------|--------------|
| 8G Fibre Channel | TRX08GVP2510 |
| Multirate 2G/4G/8G Fibre Channel | TRX08GVP2510 |

For further information please contact us at:

Web: www.mergeoptics.com

Email: info@mergeoptics.com

marketing@mergeoptics.com

sales@mergeoptics.com

technical_support@mergeoptics.com